

## Thies Precipitation Sensor

**S71100H**  
(P6362H)

- Pulse output
- Intensity-dependent linearization
- Instrument serves as sensor for quantity and intensity of precipitation, for the digital transmission of measuring values



### Description

The instrument is designed to measure the height, quantity and the intensity of the precipitation striking the surface of the earth. The measuring principle is based on the description „Guide to Meteorological Instruments No 8“ of the WMO (World Meteorological Organization).

The precipitation, collected by the collecting surface of 200 cm<sup>2</sup>, is conducted through an inflow-sieve into a tipping-bucket. After having collected the precipitation amount of 2cm<sup>2</sup> = 0.1mm, the bucket tips over. A Reed switch detects this tipping procedure and induces an output pulse for 0.1 mm of precipitation in combination with the connected electronics. As the number of tipping procedures is not linear to the precipitation intensity, an intensity-dependent linearisation is carried out in the connected electronics. The linearisation procedure is based on a precipitation-intensity-dependent pulse-number-correction for the precipitation intensity range of approx. 0.5...7 mm/min. Each instrument is calibrated in the intensity range 0... 7 mm/min with a precipitation quantity of 200 cm<sup>2</sup> (= 10 mm precipitation height).

### Dimensional Drawing

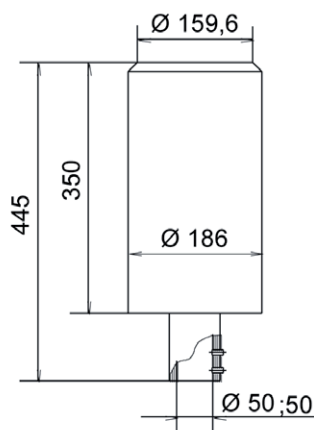

### Specifications

Characteristic	Description / Value
Catchment area	200 cm <sup>2</sup>
Resolution	0.1 mm per tip
Measuring range	max. 11mm/min.
Measuring principle	tipping-bucket
Electrical output	pulses
Ambient temperature	0 ... +60 °C (without heating) -25 ... +60 °C (with heating)
Heating	24 V AC/DC
Operating voltage	5 ... 24 V DC (2-lead circuit)
Housing	Stainless steel, non-corrosive
Montage	onto mast tube Ø 50mm
Dimensions	Ø 186 x 445 mm
Weight	3.3kg
Manufacturer	Thies / 5.4032.35.008
Accessories	Module M83500

Last Modification: 09 May 2012