

Ultrasonic Anemometer Thies 3D

S83100H
(P6007H)

- Measurement of wind direction & speed in 3 dimensions X, Y and Z
- Highest precision
- Real-time measurement
- Maintenance-free / heatable
- Digital / analog outputs and inputs



Description

The Ultrasonic Anemometer 3 D serves for the measurement of the wind direction and the wind velocity from all spatial directions. The maintenance-free and wearless anemometer needs no re-calibration, and is equipped with a heating for winter operation even under extreme conditions.

All calculations are carried out by a high-capacity digital-signal-processor (DSP) within the propagation time of the ultrasonic signals with an accuracy basis of 32 bit.

The instrument offers comprehensive statistic functions such as gliding averaging, standard deviation, co-variance etc., which can be selected via the digital interface. The gliding averaging can be set optionally in vectorial or scalar form, identically or differently for each parameter.

Dimensional Drawing

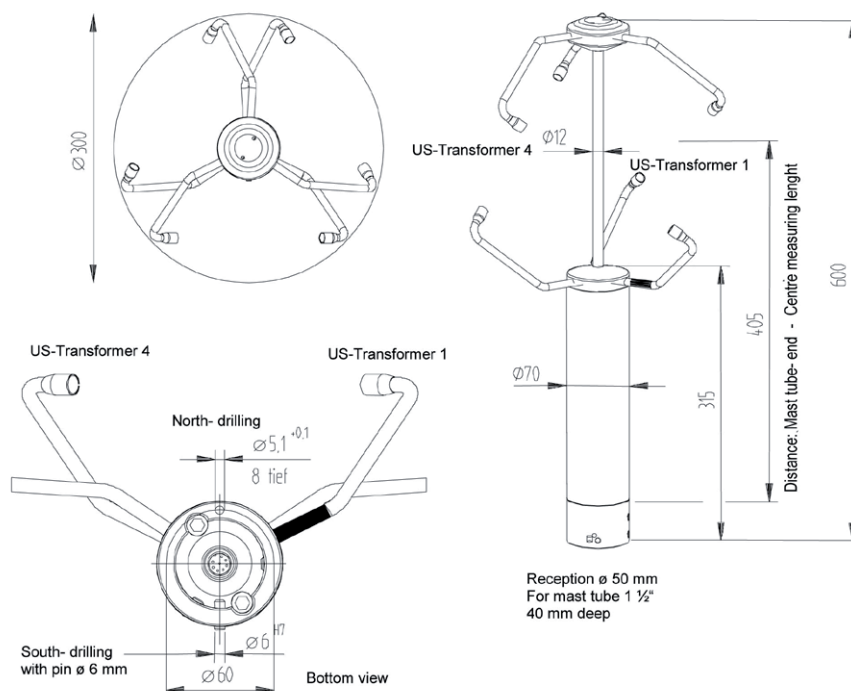

Ultrasonic Anemometer Thies 3D

S83100H
(P6007H)

Wind Speed	
Measuring range	0...65 m/s (up to 99.99 m/s is measured and output) Scaling of the analog output is freely selectable
Accuracy	≤ 5 m/s: ± 0.2 m/s; > 5 m/s: ± 2% of meas. value
Resolution	0.1 m/s (telegrams No. 1 to 4); 0.01 m/s (telegrams No. 5 to 12 and user-defined)
Wind Direction	
Measuring range	Azimuth: 0...360° Elevation: -90°...90°
Resolution	1° (telegrams No. 1 to 4), < 1° (telegrams No. 5 to 12 and user-defined)
Accuracy	±2° with wind speed > 1 m/s < 50 m/s
Virtual Temperature	
Measuring range	-40...+70°C (not specified, but useful measuring range: -75...+75°C)
Accuracy	± 0.5 K
Data Output Digital	
Interface	RS 485 / RS 422
Baud rate	1200 to 921600 adjustable
Output	Instantaneous values, wind speed / direction and acoustic virtual temp. Sliding mean values 0.5 sec to 100 min freely selectable
Output rate	1 per 1 msec to 1 per 60 sec., adjustable in msec steps
Status identification	Heating, measurement path failure, ΔT path temperatures
Data Output Analog	
Electr. output	0...20 mA / 0...10 V or 4...20 mA / 2...10 V for wind vectors X, Y and Z
Output	Wind vectors X, Y and Z, Instantaneous values, sliding mean values 0.5 sec to 100 min freely selectable
Output rate	Updating rate 0.1 Hz...100Hz
Resolution	16 bit
Analog inputs	
Input Number	Up to 5 analog inputs possible. (3x standard, 2x add. configurable acc. to manu.)
Input Resolution	16 bit
Sampling rate	0.1...100 Hz per channel
Input range	0...10 V
Data processing	Output of measured values in user-specific telegram
Accuracy	± 1% of meas. value in the range -40...+70°C
Linearity, integral	INL: type < 6LSB
Effective low-noise bits	Type 14 bit (at DC-supply for avoiding of dynamic cross-talk in the connection line)
General	
Temperature Range	Oper. temperature: -40...+70°C; Storage: -50...+80°C; with heating up to -75°C
Internal measuring rate	Up to 285 complete measurement sequences per second at 20°C
Operating voltage	Power supply electronics: 8 V to 78 V DC, 1.5 VA, max. 2.5 VA Power supply electronics + heating: 24 V AC/DC ±15%; typ. 150 VA
EMC	EN 55022: 1998 class B; EN 55024: 1998; EN 61326:1997; A3:2003
Electr. Connection	8-pole plug
Manufacturer	Thies / 4.3830.20.340

Last Modification: 2012-01-02