

Anemometer Vector

S14100 / S14100H

- Opto-electronic wind speed transmitter
- Classified according to IEC standard
- “Low Power”, high frequency output signal
- Range 0.2 ... 75 m/s
- Resolution < 0.5 m/s

In response to demand for a low power, pulse output only type, a new version of the well-known “Vector”-anemometer has been produced suitable for use with Ammonit data loggers. The sensor consumes 1 mA while operating from the logger’s battery supply.

Measurement principle

The low-inertia 3-cup rotor is set into rotation by the wind. The wheel is scanned optoelectronically and the measuring value is available at the output as a digital signal.

Mounting

The anemometer should ideally be mounted at the top of a mast to be open to the wind from all directions. Only a lightning protection rod mounted below may overtop the sensor. If an anemometer has to be mounted on a traverse the length must be at least 7 times the mast diameter.

Screw securely to mast top using a ¼” inch BSW screw directly into the base of the anemometer. The screw should not enter more than 0.38 inches; use of an excessively long screw may result in internal damage. After installation remove protection cup and lightly push rotor onto the spindle.

To remove rotor first unscrew the sensor from mast and invert instrument. Pressing the rotor hub releases the gravity sensitive catch and allows the rotor to slide off. To avoid damage due to lightning, a protection rod and proper grounding of all metal parts is to be recommended.

Dimensional drawing

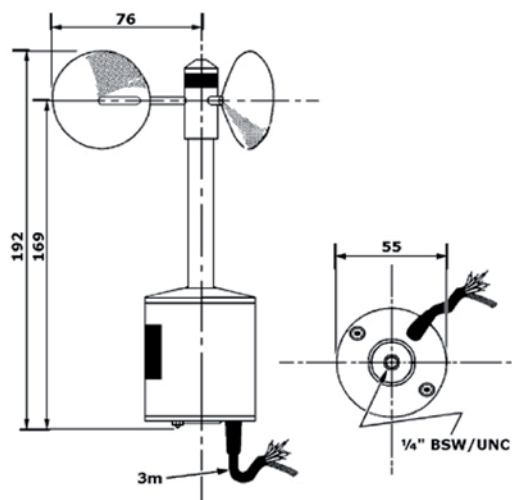

Maintenance

When mounted properly, the anemometer operates almost maintenance-free. Dust or dirt may clog the space between the rotating parts and the shaft. Therefore you should check for plausibility of measurement results at regular terms and clean the device if necessary. In true long-term operation (years) the bearings may be subject to wear and tear showing delayed start-up behaviour or even stand-still of the anemometer. Should such a defect occur we would recommend that you return the instrument for repairs.

Calibration

Frequency output is determined by a linear function of the wind speed:

$$\text{wind run [m]} = \text{pulses} \times 0.050 + 0.2 \text{ [m]}$$

For measurement campaigns with extremely crucial requirements an individual calibration of each anemometer in a wind tunnel test may be worthwhile to achieve optimum accuracy and precision.

Characteristic	Description / Value
Measurement range	0 ... 75 m/s
Accuracy	± 0.2 m/s (< 10 m/s); ± 2% of reading (> 10m/s)
Resolution	0.05 m/s
Non-Linearity	0.4 % full-range output frequency (correction curve supplied)
Starting wind speed	0.2 m/s
Survival wind speed	max. 75 m/s
Distance constant	2.3 m ± 10 %
Ambient temperature	-30 ... +70 °C
Transducer	Interruption of optical beam
Operating supply	4.75 ... 28 VDC (max 1.3 mA, average is typically less than 1 mA)
Electrical output	0 ... 1500 Hz
Termination	cable length 3 m
Materials	Anodized aluminium, weather-resisting plastics
Weight Anemometer	0.5 kg (Gross weight for shipping: 1 kg)
Recalibration	recommended interval every 24 months
Manufacturer	Vector Instruments / UK (A100LM)

Sensor Connection to Ammonit Meteo-40 Data Logger

Sensor	Manufacturer Wire Color	Ammonit Cable Wire Color*	Meteo-40 Counter	Supply Sensor
Wind speed Pulse output	white	white	CNT	
Supply	red	red		4.75 ... 28 VDC, 1 mA typ.
Ground	blue, yellow	black		GND
Heating	brown	orange, orange		24 V / 6 W, 250 mA
Heating	violet	violet, violet		

* with Junction box

Anemometer Vector Wind Speed

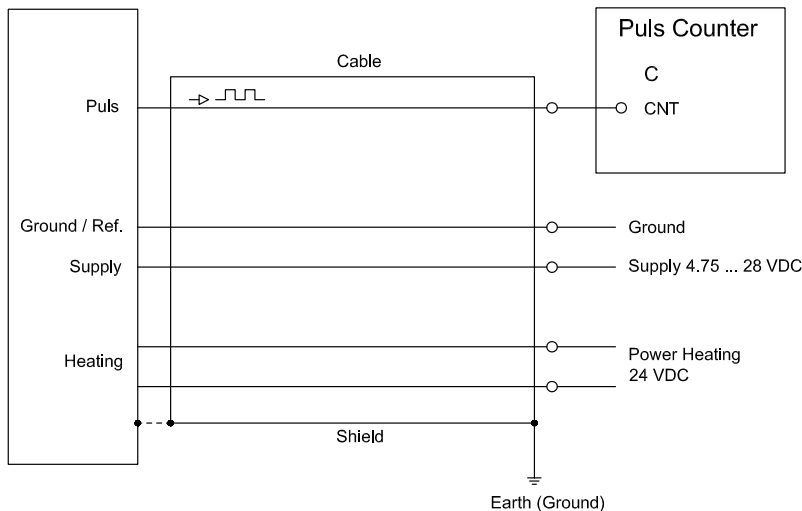

Meteo-40 Data Logger

Cable type

without heating wires:
LiY(C)Y 3 x 0.25 mm²

with heating wires:
LiY(C)Y 7 x 0.25 mm²