

- Pulse output
- Intensity-dependent linearization
- Instrument serves as sensor for quantity and intensity of precipitation, for the digital transmission of measuring values



Description

The instrument is designed to measure the height, quantity and the intensity of the precipitation striking the surface of the earth. The measuring principle is basing on the description „Guide to Meteorological Instruments No 8“ of the WMO (World Meteorological Organization).

The rain, collected by the collecting surface of 200 cm², is conducted through a inflow-sieve into a tipping-bucket. After having collected the rain amount of 2 cm³ of precipitation the bucket tips over, and the other tipping-bucket halve is ready for collecting the rain. This tipping procedure is detected by Reed-switches, and induces an output pulse in combination with connected electronics. The procedures recur with continuous precipitation.

2 cm³ tipping-bucket volume = 1 tipping-bucket puls = 0,1 mm precipitation

Output 1:

As the number of tipping procedures is not linear to the precipitation intensity, an intensity-dependent linearization is carried out in the connected electronics. The linearization procedure is basing on an intensity-dependent pulse-number-correction for the precipitation intensity range of approx. 0,5... 11 mm/min.

Each instrument is calibrated with a precipitation quantity of 200 cm³ (=10 mm precipitation height).

Output 2:

is available only as potential-free contact. This output is not linearized.

Dimensional drawing

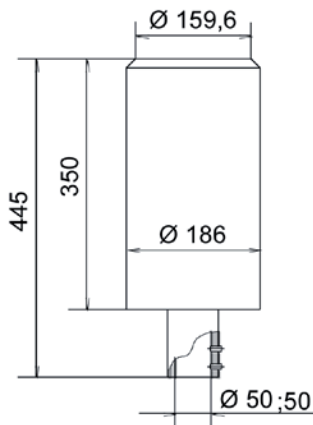

Specifications

Charateristic	Description / Value
Collector surface	200 cm ²
Resolution	0.1 mm per tipping-bucket pulse
Measuring range	0 ... 11 mm/min
Accuracy output 1 within the range of 0 ... 11 mm/min	±3 % (tested under laboratory conditions with distilled water)
Measuring principle	tipping-bucket
Ambient temperature	0 ... +60 °C (without heating), -25 ... +60 °C (with heating)
Output signal 1 (Reed contact with linearization)	
Pulse length	125 ms
Tipping-bucket frequency	0 ... 2 Hz
Operating voltage	5 VDC
Output signal 2	
Pulse length	50 ms
I Pulse frequency	0 ... 2 Hz
Contact load	max. 0.5 W
Contact voltage (Vcc)	max. 42 V
Heating	24 VAC/DC; 48.5 W
Montage	onto mast tube Ø 50 mm
Weight	3.3 kg
Manufacturer	Thies
Accessories	Module M83200 or M83570

Sensor connection to Ammonit Meteo-40 data logger

Sensor	Plug Pin No.	Ammonit Cable Wire Colour	Meteo-40 Counter	Supply Sensor
Precipitation (Output 1)	2	white	CNT (Pull-up resistor)	
Ground (Output 1)	3	blue		Main Ground
Precipitation (Output 2)	1	red	CNT (Pull-up resistor)	
Ground (Output 2)	4	black		Main Ground
Heating	6	orange, orange		24 VAC/DC
	7	violet, violet		

Cable type without heating: LiYCY 2 x 0.25 mm²
 Cable type with heating wires: LiYCY 8 x 0.25 mm²

Connect the shield logger-sided to Ground (GND)

Sensor connection diagram to Ammonit Meteo-40 data logger

